

CopperPress™ Submittal

By Merit Brass Co.



XL Press Male Adapter



Job Name	
Job Location	
P.O.#	
Engineer	
Contractor	
Wholesaler	
Merit Associate	

CopperPress™ XL Press Male Adapter is available in sizes 2-1/2" - 4" and is made of lead-free* dezincification resistant copper with an EPDM or HNBR o-ring. **CopperPress™** fittings are designed to be used with ASTM B88 Type K, L, and M 1/2" - 2" copper tubing in the hard-drawn condition and soft copper tubing in sizes 1/2" - 1 1/4".

- **Visually Indicates Pressed Ring (VIPR)** - facilitates immediate identification of un-pressed connections
- **Leak Before Press (LBP)** - in addition to the VIPR, all sizes have leak before press technology, which guarantees a visual indication if the fitting is not pressed; 1/2" has a 3 path LBP system and 3/4" & up have a 4 path LBP system
- **Permanent Application Marking** - imprinted on fitting body for quick H₂O or gas application identification
- **Lead-Free* Construction** - fully compliant with current lead-free laws
- **Copper Ends** - protect against dezincification and stress corrosion cracking

Operational Parameters: Operating/Test Pressure = 300 PSI/600 PSI, Temperature Range 0°F - 250°F

Approvals: NSF ANSI/CAN 61, UPC, cUPC, IPC, IAPMO PS-117, ICC-ES-PMG, ASME B16.51

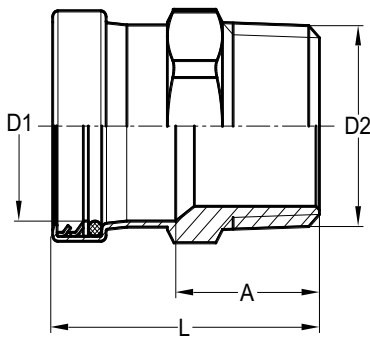

Part Number	D1 (in)	D2 (in)	L (in)	A (in)
MB22510	2-1/2	2-1/2 MPT	3.78	2.05
MB22520	3	3 MPT	4.09	2.09
MB22530	4	4 MPT	4.69	2.28

Merit Brass Company reserves the right to change any portion of the information shown on this sheet without obligation to change our press fitting line, CopperPress™, by Merit Brass Co. previously or subsequently sold. Visit www.meritbrass.com/pressfitg for the most current information. Every precaution has been taken in preparing this sheet. Merit Brass Company cannot be held responsible for omissions or typographical errors.

*Conforms with lead content requirements for lead-free plumbing as defined by the U.S. Safe Drinking Water Act. Certified <=0.25 weighted average % lead.

Find us in
MasterSpec®
Powered by Deltek Specpoint®