

DUCTILE IRON BACKUP FLANGE



Temperature °F	Working Pressure PSI	
	Class 150	Class 300
-20° to 100°	250	640
200°	235	600
300°	215	565
400°	200	525
500°*	170	495
600°	140	465
650°	125	450

* Note: The maximum temperature for ASTM A536 Grade 65-45-12 is 500°F.

Description

This specification covers Ductile Iron Backup Flanges used in piping applications as determined by Engineering as a function of what is being transported in the system, pressure ratings, temperature of material and line pressure.

Specifications

Ductile Iron Backup Flanges provided by Merit Brass Co. shall conform to ASTM A536 (65-45-12). Dimensionally, the Flanges will conform to ANSI B16.5 Class 150. Pressure & Temperatures are governed by ASME B16.42 Class 150 specifications.

Project Information	Approval Stamp
Project Name:	Approved
Project Location:	Approved As Noted
Project Contractor:	Not Approved
Project Engineer:	Remarks:
Project Distributor:	
Project Rep:	
Submittal Date:	
Notes 1:	
Notes 2:	

Please visit meritbrass.com. Some items not shown may be available upon request. Some items and sizes may be discontinued when stock is depleted and may require a minimum order quantity. Certain inventory limitations may apply. Priced on application (POA). For list prices in Excel, download by please logging onto meritbrass.com. Contact our Sales Team for details at sales@meritbrass.com. Every precaution has been taken in preparing this submittal, however, Merit Brass Company cannot be held responsible for typographical errors or omissions.

DUCTILE IRON BACKUP FLANGE

Part #	Size (In)	Aprox. WT. (Lb)	BC	ID	OD	T	Bolts
ADI-08	1/2"	0.95	2.38	0.09	3.50	0.44	4
ADI-12	3/4"	1.45	2.75	1.11	3.88	0.50	4
ADI-16	1"	1.60	3.13	1.38	4.25	0.50	4
ADI-20	1-1/4"	1.82	3.50	1.72	4.63	0.50	4
ADI-24	1-1/2"	2.15	3.88	1.87	5.00	0.50	4
ADI-32	2"	3.00	4.75	2.44	6.00	0.50	4
ADI-40	2-1/2"	4.15	5.50	2.94	7.00	0.50	4
ADI-48	3"	4.00	8.00	3.56	7.50	0.50	4
ADI-64	4"	6.78	7.50	4.56	9.00	0.56	8
ADI-96	6"	9.42	9.50	6.75	11.00	0.63	8
ADI-128	8"	11.90	11.75	8.75	13.50	0.63	8
ADI-160	10"	16.95	14.25	10.88	16.00	0.63	12
ADI-192	12"	26.43	17.00	12.88	19.00	0.75	12

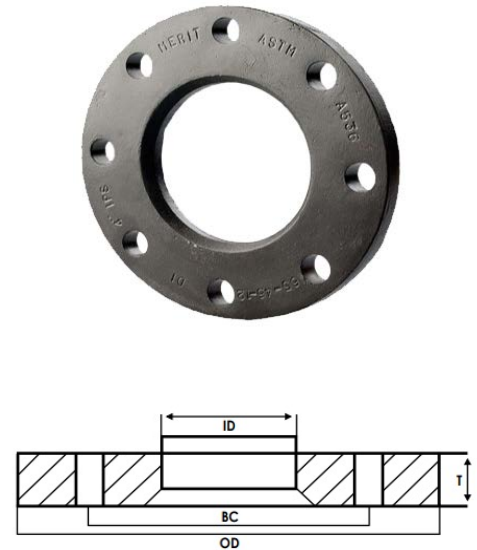

GALVANIZED DUCTILE IRON BACKUP FLANGE

Part #	Size (In)	Aprox. WT. (Lb)	BC	ID	OD	T	Bolts
AGDI-16	1"	1.60	3.13	1.38	4.25	0.50	4
AGDI-20	1-1/4"	1.82	3.50	1.72	4.63	0.50	4
AGDI-24	1-1/2"	2.15	3.88	1.87	5.00	0.50	4
AGDI-32	2"	3.00	4.75	2.44	6.00	0.50	4
AGDI-40	2-1/2"	4.00	5.50	2.94	7.00	0.50	4
AGDI-48	3"	4.00	8.00	3.56	7.50	0.50	4
AGDI-64	4"	6.78	7.50	4.56	9.00	0.56	8
AGDI-80	5"	7.28	8.50	5.62	10.00	0.63	8
AGDI-96	6"	9.42	9.50	6.75	11.00	0.63	8
AGDI-128	8"	11.90	11.75	8.75	13.50	0.63	8
AGDI-160	10"	16.96	14.25	10.88	16.00	0.63	12
AGDI-192	12"	26.43	17.00	12.88	19.00	0.75	12

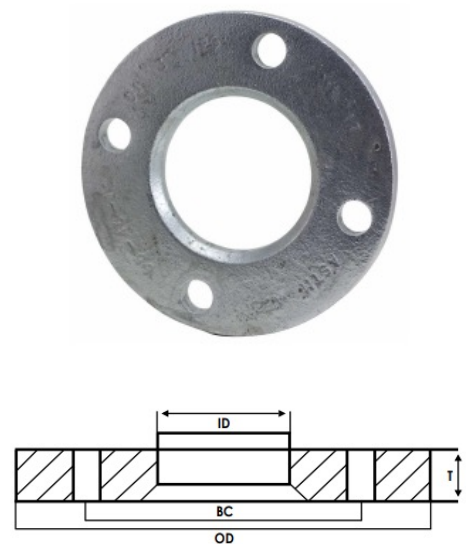

LOCATIONS

SPARKS DISTRIBUTION CENTER
200 Vista Boulevard Suite #106
Sparks, NV 89434

LONG BEACH PIPE DEPOT
2396 E. Artesia Blvd
Long Beach, CA 90805

DALLAS DISTRIBUTION CENTER
10614 King William Drive
Dallas, TX 75220

CLEVELAND HEADQUARTERS
One Merit Drive/PO Box 43127
Cleveland, OH 44143

BIRMINGHAM DISTRIBUTION CENTER
220 Oxmoor Court
Birmingham, AL 35209

HOUSTON DISTRIBUTION CENTER
4680 S. Sam Houston Pkwy W, Suite 120
Houston, TX 77053

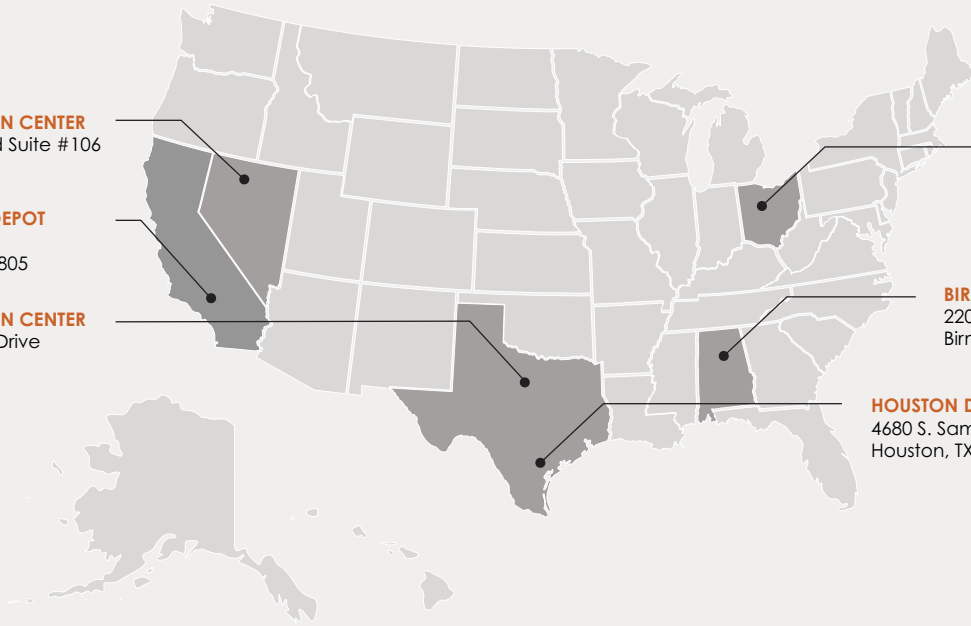

SHIPPING TIMES

UPS

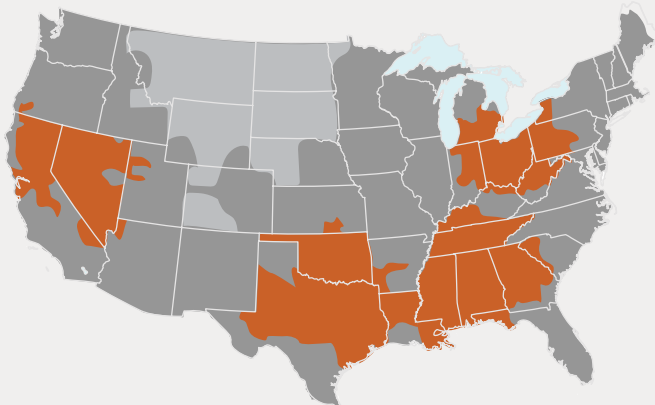

1 Day 2-Days 3 Days

FedEx

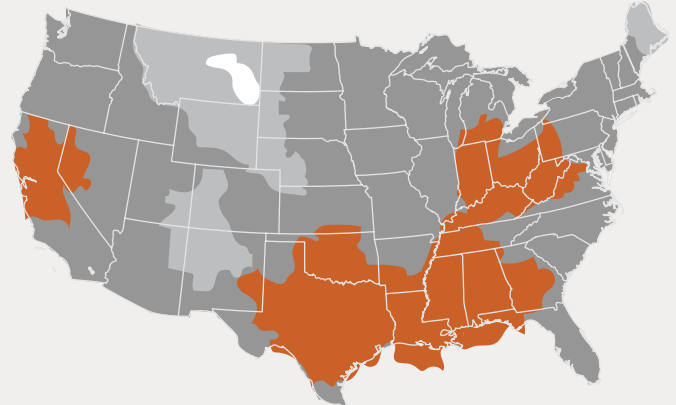

1 Day 2 Days 3 Days 4 Days

*FedEx is Merit's Primary Carrier

LEARN MORE

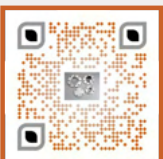

800.726.9800

Follow us on

www.meritbrass.com
www.mbwebxpress.com
contactus@meritbrass.com

Merit Brass Headquarters Has An ISO 9001:2015 Registered Quality Management System